

Tiger Stock Ltd

Data sheet EDWHM100

Background Ventilator Trickle Passive Purge Vent Natural Ventilation Wall Grille 100mm



Key Features

- 100mm Wall Diameter: Designed for installation in standard 100mm (4") walls.
- Controls Mould & Condensation: Effectively reduces moisture and inhibits mould growth.
- Adjustable Iris Shutter: Provides manual control over airflow and air replacement.
- Washable Filter: Prevents dust and particles while allowing air exchange.
- Versatile System Use: Works with PIV, negative, background, or mechanical extract systems for air replacement and humidity control.

Description:

Passive Ventilation Vents serve as a robust solution for passive condensation, mould, humidity, and moisture control. Whether used independently or in conjunction with other ventilation systems, these vents excel at reducing mould growth, condensation buildup, and excessive humidity levels, all while facilitating the circulation of fresh air in and out of your space.

The iris-type shutter inside the passive vent allows precise regulation of condensation, moisture, humidity, and air movement. Adjust the airflow effortlessly using the slider at the bottom of the grille or the provided pull cord, particularly useful for high-level installations.

When employed as a fresh air intake vent, the internal membrane filter acts as a protective barrier, preventing noise, dust, and airborne particles from entering your kitchen, wet rooms, and living

areas, while simultaneously reducing the risk of mould, condensation, and humidity. Simultaneously, it replaces stale air, ensuring a continuous flow of fresh, healthy air.

For rooms prone to high levels of humid, dirty air, such as bathrooms, showers, kitchens, and utility rooms, the iris shutter can be opened to increase airflow through the passive vent, effectively combating humidity issues, mould growth, and providing much-needed air replacement.

The EDWH100 vent will enhance air quality, reduce mould, condensation, and humidity, and replace stale air, creating a healthier, more comfortable living or working environment. Achieve optimal comfort and well-being with our Passive Wall Vent Condensation, Mould, Humidity Control, and Air Replacement Ventilator.

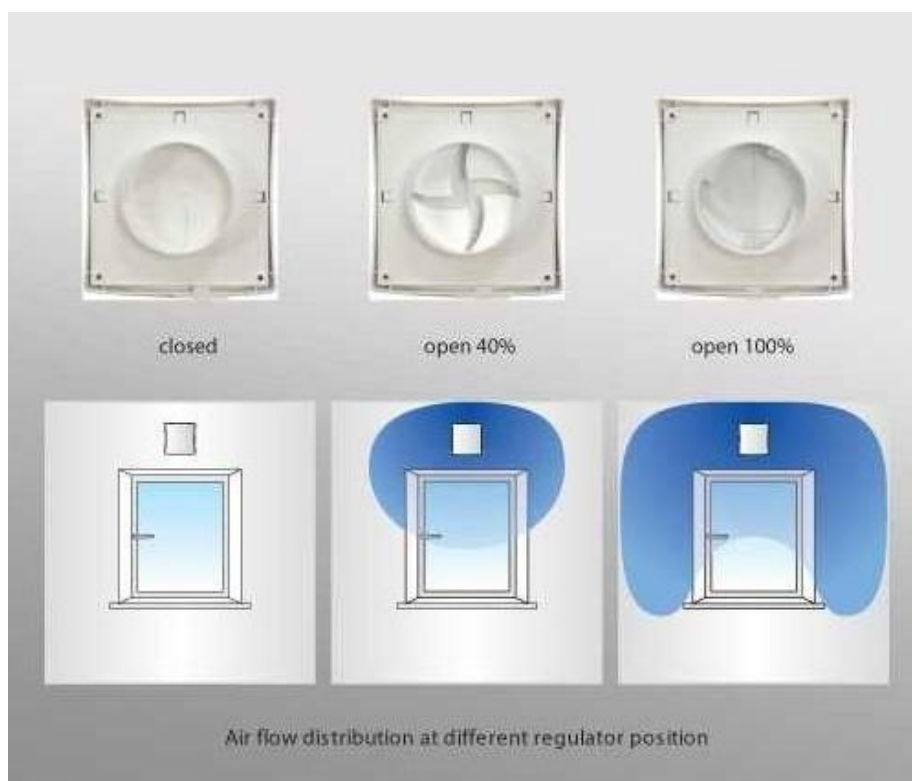
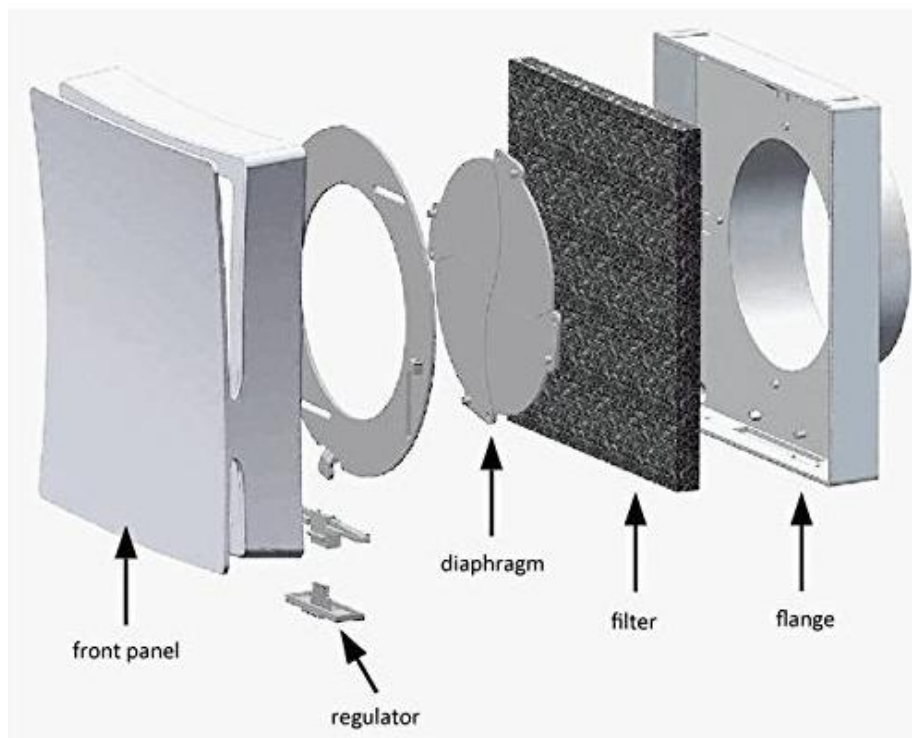

Overall Dimensions (mm)

Internal grille

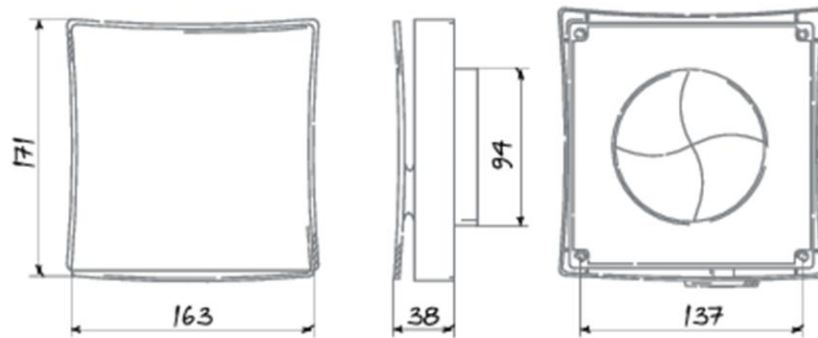

Technical Data

